

Gozinta® Force Transducer

FEATURES

- Simple press fit mounting
- Stainless steel construction
- Hermetically sealed
- Corrosion resistant
- Low temperature sensitivity
- Field installable into existing structures
- Measures tension, compression, shear, bending, torsion
- Full double bridge configuration
- Single capacity for all applications

APPLICATIONS

- Agricultural equipment
- Rolling mill sensing
- Stamping press control
- Lift trucks
- Machine tool wear sensing
- Intrusion alarms
- Structural load measuring
- Moment sensing
- Tank weighing systems
- In-rail weighing systems

DESCRIPTION

An innovative approach to sensor design combined with proven strain gage technology has resulted in a small, accurate stainless steel sensor with wide-ranging application possibilities. The Gozinta® overcomes a



number of current sensor problems and limitations such as installation ease, size, load limit, location and operating temperature conditions. In addition, the Gozinta® has unchallenged application versatility and a wide range of machines, devices or structures can use Gozinta® sensors as a cost-effective, accurate solution to sensing needs.

The Gozinta® sensor is mounted into the machine or structure and the sensor's output can be calibrated to meet the system needs.

As a result, the maximum load of the system is determined by the structure, rather than by the sensor. Sensitivity to thermal effects is minimal due to the Gozinta®'s unique patented design.

The Gozinta® is configured with a full bridge circuit for low non-linearity, hysteresis and non-repeatability. A certain degree of care should be taken when positioning or locating the sensor in a structure. In addition, the number of sensors used in a structure, the amount of strain an individual Gozinta® senses, and the material of the structure will affect the overall accuracy. Installation is optimized through the use of specific installation tools, supported by extensive application notes.

OUTLINE DIMENSIONS in millimeters

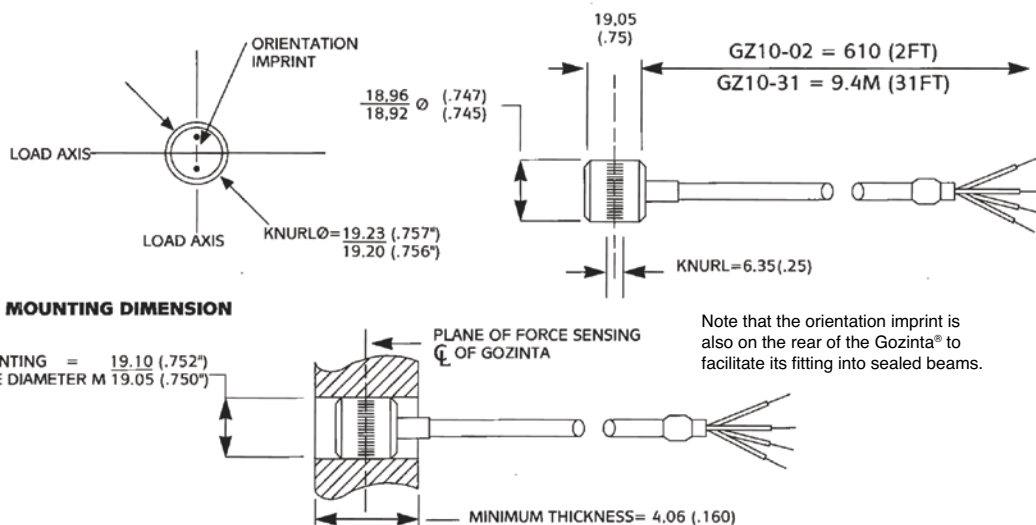

Gozinta® Force Transducer

SPECIFICATIONS		
PARAMETER	VALUE	UNIT
Excitation voltage	up to 15	VAC/VDC
Zero balance	0.00±0.05 (Prior to installation)	mV/V
Bridge configuration	Full/Double bridge	
Input resistance	700±20	Ω
Output resistance	700±20	Ω
Insulation resistance	≥5000	MΩ
Nonlinearity	±1.0	% FS ¹
Hysteresis	±0.05	% FS ¹
Non-repeatability	±0.1	% FS ¹
Temperature coefficient: Output	0.036	% of reading/°C
Zero	0.35 (-1° to +45°C)	% FS/°C
Temperature range: Storage	-50 to +90	°C
Temperature range: Operating	-40 to +80	°C
Maximum safe output ⁽²⁾		
Tension	2.5	mV/V
Compression	2.5	mV/V
Shear	4.0	mV/V

⁽¹⁾ Specifications for the Gozinta® GZ-10 installed into a mild steel test block (90 x 38 x 305) and subjected to a tensile force of 24000N. Nominal output is 1mV/V. Other specifications are given for uninstalled GZ-10.

⁽²⁾ The maximum safe output for the Gozinta® based on 10⁴ full negative to full positive operating cycles (zero to minus to plus to zero).

Caution: The endurance limits of the beam must be determined separately.

All specifications subject to change without notice.

Wiring Schematic Diagram

